

Coverage Pattern And Plan View

HORIZONTAL COVERAGE

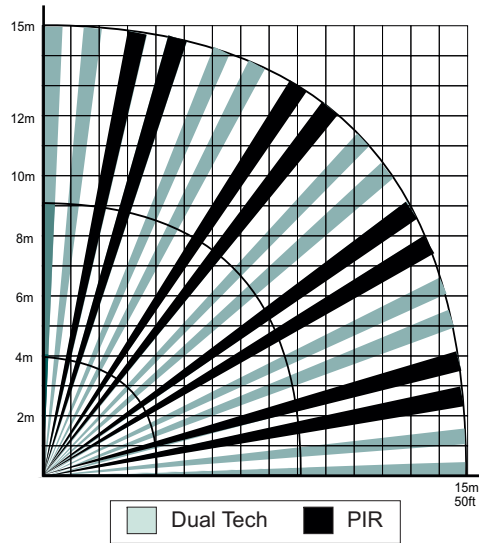

VERTICAL COVERAGE

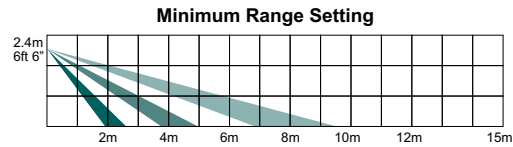
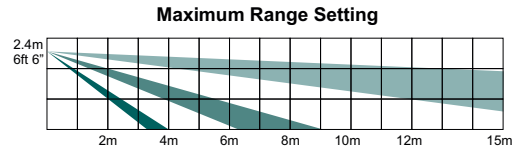

Dual Tech Lens

Volumetric
90°
30 Zones
3 Planes

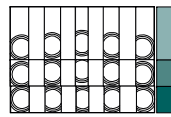

PIR Lens

Volumetric
69°
24 Zones
3 Planes

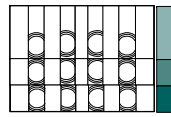

Operation of Features

Initial Power Up
On first power up of the TMD15G3, the detector will go into a self test, this will involve the GREEN and ORANGE LEDs flashing on the dual tech, and the RED LED flashing on the PIR. After a minute the detector will be ready. If the ORANGE LED is still flashing then the detector has failed a Microwave test, or if the GREEN LED or RED LED is still flashing then the detector has failed a PIR test, if this occurs try restarting the detector (powering down and back up).

Self Test
Every 5 hours of detector none activity the detector will do an active diagnostic self test. If in the unlikely event of a failed self test the detector anti-mask/fault relay will open.

Low Voltage Detect
If the detector detects a low voltage fault, then the anti-mask/fault relay will open.

The EN anti-mask Operation
FOR EN OPERATIONS DIP SWITCH 6 MUST BE ON
If an attempt is made to anti-mask the TMD15G3 the BLUE LED will start flashing at half a second intervals, signaling that the detector is going into 'anti-mask processing'. anti-mask processing will take 60 seconds to complete.
If the detector still sees an anti-mask after 60 seconds then the anti-mask/fault and Alarm relays open, and the GREEN and ORANGE LEDs will be illuminated.
For None EN operation just the anti-mask/fault relay goes open. To select which relays to open on an anti-mask activation see dip switch 6. To reset the detector to normal operating mode, remove the blocking material, the BLUE LED will then flash again and during this time the detector should be walk tested to activate both Microwave and PIR, the GREEN and ORANGE LED will be extinguished after 60 seconds and the relays will be closed again. If the detector has been put into anti-mask processing by accident, you will need to walk test the detector so both the Microwave and PIR trigger, after 60 seconds the BLUE LED will stop flashing and normal operation is resumed.

Switch 1. 50/60Hz
ON = 50Hz OFF = 60Hz

Switch 2. Anti-mask Mode
This controls when the anti-masking algorithm is applied. When the DIP switch is ON (Default), the anti-masking algorithm is enabled regardless of the set/unset status of the detector. When the DIP switch is OFF, the anti-masking algorithm is enabled when the RI1 is in the unset state.

Switch 3. Blocking
ON = Blocking Disabled / OFF = Blocking Enabled
'Blocking' works as follows: If an attempt to anti-mask the detector is made when the control panel is disarmed, the alarm relay will be held open until the anti-masking is removed (thus not allowing the control panel to arm). You must also connect the "RI 1" input on the TMD15G3 to a programmable output. When the control panel is disarmed, this input must be at 0V. When the panel is armed it must be at 12V. To enable this feature dip switch 3 must be OFF.

Switch 4. RI 1 Mode
A link on board marked "RI1/Spare" determines if the RI1 terminal is used for the set/unset signalling or simply as a spare terminal to aid EOL wiring. If the RI1/Spare link is fitted, the state of RI1 determines if the panel is set or unset. The actions that can be performed in set and unset mode are also determined by DIP switch 4 and 2. DIP switch 4 controls the action of RI1. If the switch is ON the detector will operate permanently in Set Mode. When DIP switch 4 is OFF, the detector will use the state of RI1 to determine the set or unset state. A 0V applied to input RI1 is interpreted as being unset. A +12V applied to input RI1 is interpreted as being set. DIP switch 2 determines if anti-masking is enabled all of the time or only when the panel is unset. When nothing is connected to RI1, the input state is in the set state.

Switch 5. Dual Tech (Alarm 1) Sensitivity
ON = Auto Sensitivity / OFF = High Sensitivity
The bottom PIR will always remain in Auto Sensitivity

Switch 6. Anti-anti-mask Relay Action
FOR EN OPERATION DIP SWITCH 3 MUST BE OFF
ON = Open Both anti-mask and Alarm Relays
Example of a control panel input looking for a anti-mask value of 13k7. See below
Alarm relay = 4k7, Tamper EOL = 2k2, anti-mask/Fault relay = 6k8.
None EN operation only anti-mask relay opens.
OFF = Opens anti-mask Relay Only
Example of a control panel input looking for a anti-mask value of 14k2. See below
Alarm relay = Closed, Tamper EOL = 2k2, anti-mask/Fault relay = 12k.

Switch 7. Operational mode
ON = TMD Mode.
DIP Switch 7 determines the operational mode of the detector. When the switch is ON (default) will operate as a TMD15G3, where the Dual Tech and the Single PIR operate independently.
To open alarm contact 1, the Dual Tech's PIR must trigger within a given time period of the microwave sensor. Alarm contact 2 is based on the operation of the Single PIR only.
OFF = TriCover® Detector Mode.
When switch 7 is OFF, the detector will operate as a TriCover® detector, with all technologies needing to trigger within a given time period of each other to open alarm contact 1. Alarm contact 2 will operate in the inverse of alarm contact 1. In alarm, the only LED to be illuminated will be the Dual Tech alarm LED.

Switch 8. LED Enable/Disable
ON = LED Enable / OFF = LED Disable
To remotely enable the LEDs 0V must be applied to the "LED" terminal. If used with Pyronix panels, the LED terminal must be connected to a PGM output and programmed as "Remote LED Enable".
For Standard G3 operations the DIP switches do not need to be adjusted.



EN50131-2-4:2008
EN50131-1-1:2006+A1:2009
PD6662:2010
Security Grade 3
Environmental Class 2

TMD15[®]

GRADE 3

INTERNATIONAL

Pyronix
www.pyronix.com

TMD15[®] Specifications

Model:	TMD 15 [®] 15m Internal detector
Colour:	WHITE
Casing:	3mm ABS, 0.4mm HDPE in Lens Area
Lenses:	2 Volumetric Lenses, with NO overlapping zones
Detection Method:	2 Low noise dual element passive infrared sensors and a microwave doppler unit
Dual Tech Sensitivity:	Selectable AUTO or HIGH
Temperature Compensation:	Digital
Microwave Detection Range:	15m PIR and 1-15m microwave
anti-mask Detection Range:	0m - 1m anti-masking
Detection Zones:	27 facets, 54 zones in total. Top Lenses: 5 columns, 15 facets, 30 zones 90 field of view non-overlapping zones Bottom Lenses: 4 columns, 12 facets, 24 zones 69 field of view non-overlapping zones
Detection Speed:	0.25 - 2.5m/s
Operating Voltage:	9-16Vdc, 13.8Vdc typically
Current Consumption:	30mA @ 13.8Vdc Quiescent
Relay Output:	3 x SELV limits; 60Vdc 50mA (42.4Vac peak)
Mounting Height:	1.8 - 2.4m = 15m, 3m = 12m
Certified Mounting Height:	2.4m (mount at this height for the coverage shown)
Tamper Switch:	12Vdc 50mA both front and rear
Storage Temperature:	-40°C to +80°C
Nominal Operating Temp:	-30°C to +70°C
Certified Operating Temp:	-10°C to +40°C
Emissions & Immunity:	EN55022 Class 2, EN50130-4

Suggested Specification Detail:

A dual technology (PIR/Microwave) movement detector having a range capability of 15 metres and five detection columns within an overall angle of coverage of 90 degrees. This is non-overlapping with a PIR movement detector, which has a range capability of 15 metres and four detection columns with an overall angle of coverage of 69 degrees installed in the (location) and at a height of (x) metres.

Switch Options

SWITCH	FEATURE	POSITION	MEANING
1	50/60Hz	ON	50Hz
		OFF	60Hz
2	Anti-mask	ON	24 Hour
		OFF	Anti-mask only enabled in unset mode
3	Blocking	ON	Blocking processing Off
		OFF	Blocking processing On
4	RI1 Mode	ON	Permanent in Set Mode
		OFF	State of RI1 = set/unset mode
5	Sensitivity	ON	Dual Tech = AUTO
		OFF	Dual Tech = HIGH
6	anti-mask	ON	Open anti-mask & Alarm relays when in anti-mask
		OFF	Open anti-mask relay only when in anti-mask
7	Operational Mode	ON	Two movement detector
		OFF	TriCover® detector
8	LED Enable	ON	Enable LEDs
		OFF	Disable LEDs



For electrical products sold within the European Community. At the end of the electrical products life, it should not be disposed of with household waste. Please recycle where facilities exist. Check with your Local Authority or retailer for recycling advice in your country.

INTERNATIONAL

This product is approved for use in the Residential, Commercial and Light Industrial Environment.



EN50131-2-4:2008
EN50131-1:2006+A1:2009
PD6662:2010
Security Grade 3
Environmental Class 2

This product complies with EN50131-2-4, at security grade 3, environmental class 2.
UK = Suitable for use with systems installed to PD6662:2010
EXPORT = Suitable for use with systems installed to EN50131-1:2006+A1:2009

Customer Support Line (UK only):
+44(0)845 6434 999 or or +44(0)1709 535225

Hours: Mon to Fri, 8:00am till 6:30pm
Email: customer.support@pyronix.com
Website: www.pyronix.com
Pyronix Limited, Pyronix House, Braithwell Way, Hellaby, Rotherham, S66 8QY. UK

WARRANTY

This product is sold subject to our standard warranty conditions and is warranted against defects in workmanship for a period of five years.

In the interest of continuing improvement of quality, customer care and design, Pyronix Ltd reserves the right to amend specifications, without giving prior notice.

RINS1474-3

The Installation Of The TMD15®

Case Lid Screw Fitting



Casing Knockouts

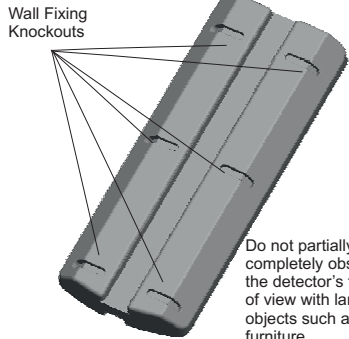

Wall Mounting

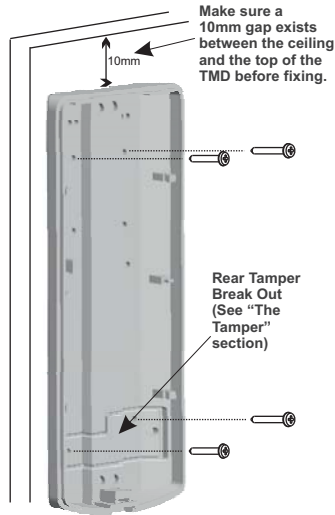

NOTE: When mounting the TMD 15®, ensure that it is mounted vertically

The Tamperers

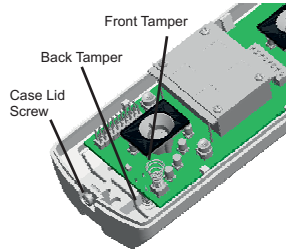

The back tamper operates by the use of the "rear tamper break out" section of the TMD 15®. If the detector is forcibly removed the "rear tamper break out" stays attached to the wall, thus opening the back tamper.

Dip Switches

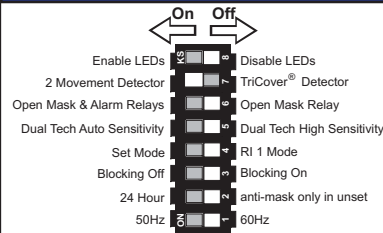

PIR Range

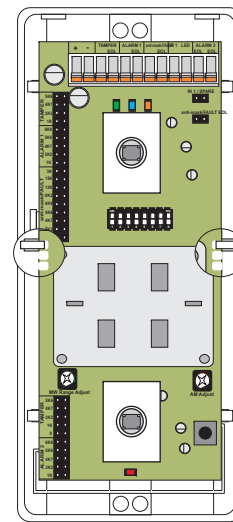

The 'notches' as shown above, alter the range of the PIR from 5m to 15m.

Top = 15m
Middle = 10m
Bottom = 5m

Physical Layout

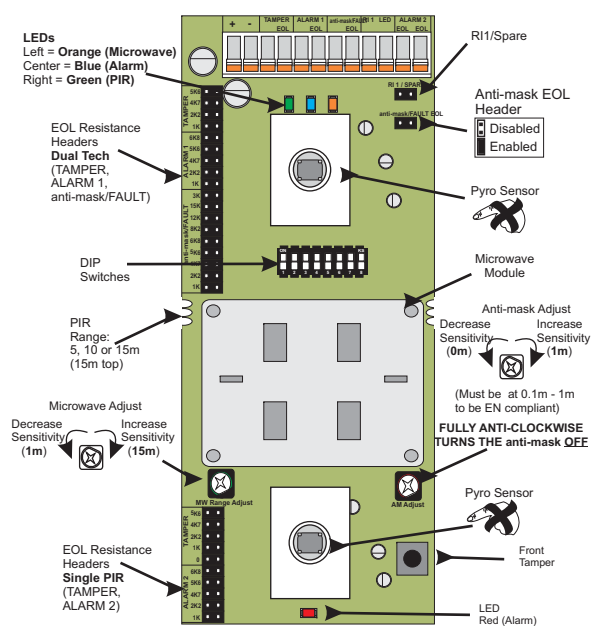

The Wiring Connections For The TMD15® (Examples)

Grade 3 Configuration (DEOL)
TriCover® mode configured to a single input with anti-mask configured to a second input

NOTE: DIP SWITCH 7 MUST BE OFF

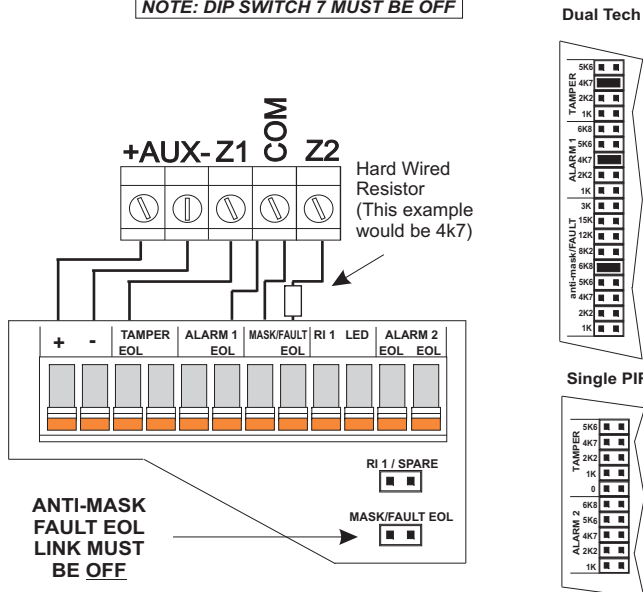

Grade 2 Configuration
TriCover® Mode SEOL Wired to a single input with anti-mask configured to a second input

NOTE: DIP SWITCH 7 MUST BE OFF

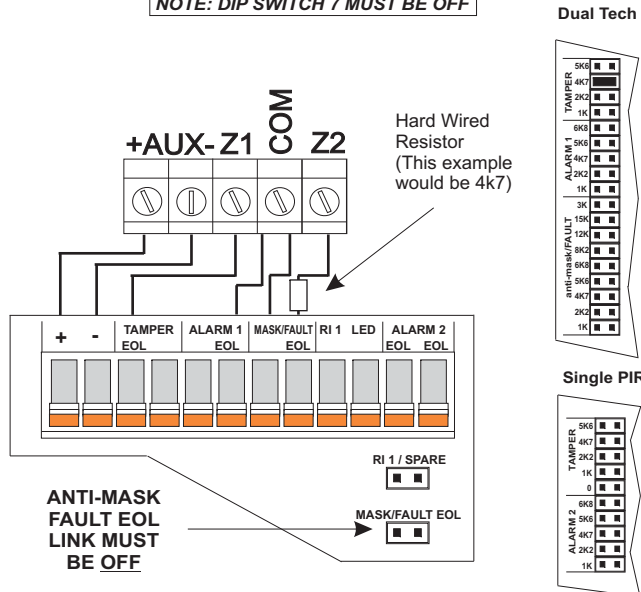

Grade 2 Configuration
Dual Tech and Single PIR Technologies Configured To Separate Inputs (SEOL)

Dual tech to input 1
Single PIR to input 2

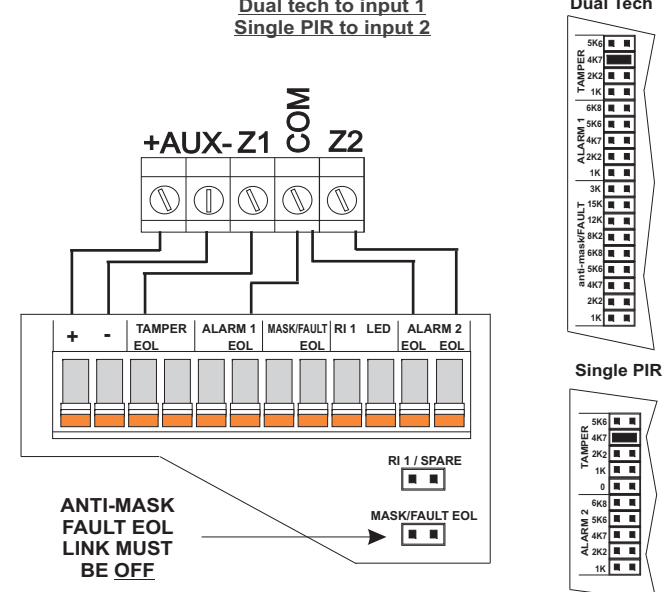

NOTE: IF THE RESISTOR VALUES THAT YOU REQUIRE ARENT SHOWN, PLEASE CONTACT CUSTOMER SUPPORT.